

# Child's Chair

## Construction and Assembly Instructions

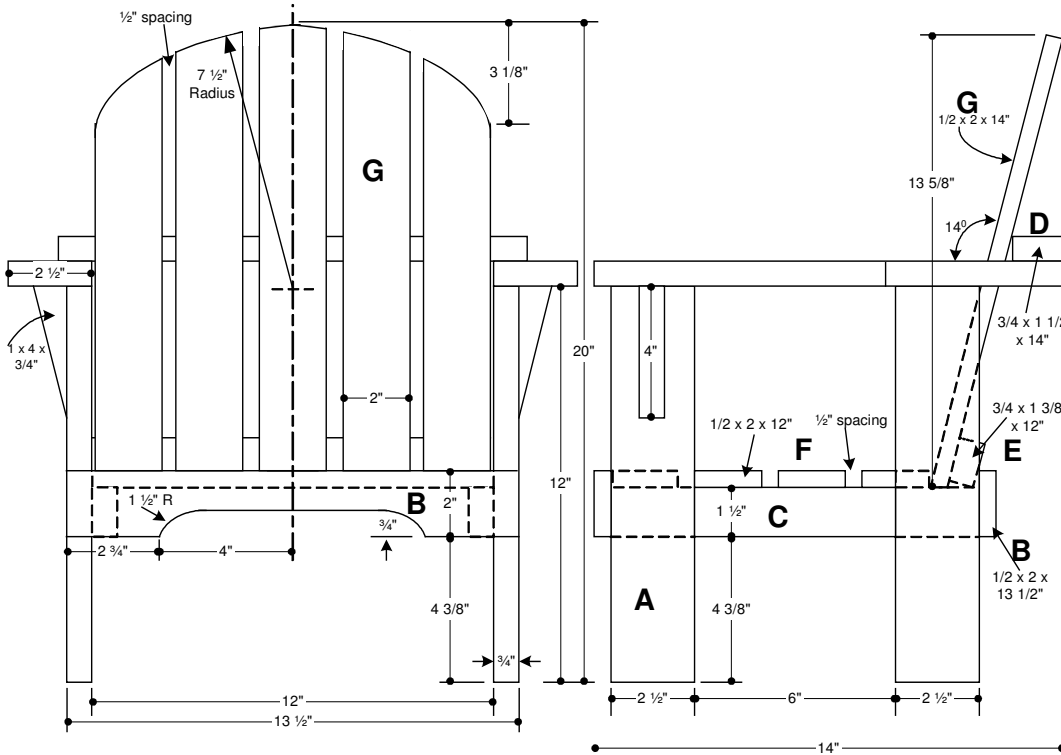

R. H. Fritz  
October 2004

# *Child's Chair*

## *Construction and Assembly Instructions*

---

Updated 8/4/05

### **1. OVERVIEW:**

This chair is fun and comparatively easy to make. I've made several and have also designed an Adirondack version. My granddaughter began using it when she was about 16 months old. The chair material is from  $\frac{3}{4}$ " and  $\frac{1}{2}$ " pine and fastened using glue nails and screws. Once glued and screwed it is very strong and sturdy.

### **2. CUT ALL PIECES:**

1. I find the assembly easier and faster if I cut all the  $\frac{3}{4}$ " pieces to size first.
2. If you have a planer then cut the  $\frac{1}{2}$ " pieces to size from  $\frac{3}{4}$ " stock and run these through the planer to  $\frac{1}{2}$ ". The seat and back pieces are made from  $\frac{1}{2}$ " stock as well as the front and back seat braces (B).
3. Layout and cut the wedge piece (I) from each arm rest (H) and set aside for later use. Now, cut the radius on the front of each arm and make sure that the larger  $2\frac{1}{4}$ " radius is on the outside edge of the arm.
4. Layout and cut the curved recess on the front seat brace (B).

### **3. ASSEMBLE CHAIR FRAME AND SEAT:**

1. Attach the left and right seat brace (C) to the legs (A) using glue and  $1\frac{1}{4}$ " screws from the inside of (C).
2. Attach back brace (B) using glue and nails then attach front brace (B) with glue and nails. Note that the position of the bottom of the front and back brace (B) is even with the bottom of the left & right braces (C). This will allow the seat to be flush with the top of the front brace.
3. Sand the 4 seat pieces (F) and attach using glue and nails. Use  $\frac{1}{2}$ " spacers between each seat piece.
4. Attach the 2 arms using glue and  $1\frac{1}{4}$ " screws. Attach the 2 arm braces (I) using glue and one nail in each.

### **4. ASSEMBLE AND ATTACH THE CHAIR BACK:**

1. Lay the 5 seat back pieces (G) on the workbench using  $\frac{1}{2}$ " scrap spacers between each piece and align the bottoms.
2. Mark the seat back curve by scribing a  $7\frac{1}{2}$ " radius along the top of the seat from the center of the seat back.
3. Cut the curve on each piece and sand smooth. Sand and break the edges on the seat back pieces.
4. Cut or plane an angle on the front edge of the upper seat brace (D) to match the angle of the seat back. Approx. 14 degrees.
5. Lay the 5 seat back pieces (G) back on the workbench using  $\frac{1}{2}$ " scrap spacers between each piece and attach the lower back brace (E) using glue and screws.
6. Place the upper seat brace (D) on the back of the chair arms using small clamps and place the seat back in the chair to see if the fit is appropriate and the angle of the upper seat brace (D) is correct. Fine-tune the angle on the upper seat brace (D) to match the angle of the seatback if necessary.
7. Remove the seat back and attach upper seat brace (D) using glue and screws.
8. Replace the seat back and attach the lower seat brace (E) with  $1\frac{1}{4}$ " screws driving them through the legs (A) into the seat brace (E).

*Child's Chair*  
*Construction and Assembly Instructions*

---

Updated 8/4/05

9. Attach the seat back to the upper seat brace (D) using glue and nails.

<b>5. FINISH:</b>
-------------------

1. Finish sand all surfaces and edges.
2. The chair can be stained and finished with several coats of Polyurethane or sprayed with paint. Accent decals add a special look as well.

# Child's Chair

## Construction and Assembly Instructions

Updated 8/4/05

### Material

- |                         |                             |
|-------------------------|-----------------------------|
| (4) 3/4" x 2-1/2" x 12" | (A) Legs                    |
| (2) 1/2" x 2" x 13-1/2" | (B) Front & Back Seat Brace |
| (2) 3/4" x 1-1/2" x 11" | (C) L&R Seat Brace          |
| (1) 3/4" x 1-1/2" x 14" | (D) Upper Back Brace        |
| (1) 3/4" x 1-3/8" x 12" | (E) Lower Back Brace        |
| (4) 1/2" x 2" x 12"     | (F) Seat Slats              |
| (5) 1/2" x 2" x 14"     | (G) Back Slats              |
| (2) 3/4" x 2-1/2" x 14" | (H) Arms                    |
| (2) 3/4" x 1" x 4"      | (I) Arm Bracket             |

